

deehan



DOOHAN Intelligent Electric Motorcycle

DH01 Intelligent Electric Motorcycle

Product use instructions

Executive standard: 168/2013/EU

Q/ZGDQ·001

Zhejiang Doohan Technology Corp LTD

Preface

Thank you for purchasing DH01 intelligent electric motorcycles, and sincerely welcome you to join the ranks of driving right three-wheel motorcycles and enjoying a safer driving. Before driving, you must be thoroughly familiar with the contents contained on this manual. Your personal safety and security, not only depends on your own watchfulness and familiarity with the operative technology, but also is related to your familiarity with mechanical properties of the right three-wheel electric motorcycle. Each time before driving, check and regular maintenance is the most basic conditions. If you need regular maintenance or repair, then you must know that, only the Special Maintenance Department of the company in various regions, knows how to handle the problems and ensure the product's optimum performance. If you have relevant machinery technical knowledge and maintenance tools, special sales shop can provide a list of spare parts and a wide variety of authentic spare parts to help you for the better maintenance and repair.

This operating manual elaborates on the main points of correct operational approaches, simple maintenance and adjustment method, of DOOHAN DH01 intelligent electric motorcycle, in order to expect its durable usage. If technical specifications change, parts of pictures or content in this manual may have little differences with the actual conditions of motorcycles, please be understanding. The company reserves the right of final interpretation.

Hope you enjoy your driving, once again thank you for purchasing DOOHAN DH01 intelligent electric motorcycles.

Important notes

- Driver and passenger
- This motorcycle is designed for only one driver to operate. Never exceed the load weight provided on this manual.
- Road Conditions
- This motorcycle shall only be driven on the normal road. The motorcycle can be driven in the rain and snow, but cannot wade. When water flooded in to the center shaft, it may cause the electrical machinery, batteries or other parts filled with water or failure. Considering of safety factors, please abide by traffic regulations, and slow down in the rain and snow days and on slippery areas, increase braking length to ensure safety when braking.
- Warnings on safety and environmental protection should be pasted on the middle of head back cover outside, glove compartment cover upside and back shelf upside (clearly visible before or during the using).
- For the safety of others, please do not lend your motorcycle to those who do not have a driving license and lack of driving experience, and thus also your motorcycle can be safe from unnecessary damages.
- Please read this operation manual carefully.
- Where marked with the warning sentences or paragraphs shall be paid particular attention.

Warning:

It means that if not abiding by the instructions in the manual, your operation may cause serious casualties.

Attention:

It means that if not abiding by the instructions in the manual, your operation may make people injured or machine parts damaged.

This manual shall be regarded as a permanent part of the right three-wheel electric motorcycle. Even though the motorcycle is transferred to others, this manual shall be transferred too.

Contents

- I、 Safe Driving of intelligent electric motorcycles.
- II、 Position drawing of every machine part and operation manual
- III、 Daily inspection and adjustment
- IV、 Operation guidance
- V、 Maintenance and repair
- VI、 Common Fault and elimination methods
- VII、 Vehicle Storage
- VIII、 Vehicle Identification
- IX、 Main technical data
- X、 Electrical schematic diagram (DH01)

I Safe Driving of Right Three-wheel Electric Motorcycle

Safe Driving Regulations

1. Many traffic accidents of right three-wheel motorcycles are caused because car drivers fail to see intelligent electric motorcycles drivers, therefore, right three-wheel electric motorcycle drivers should try to enable car drivers to see them clearly, for example:

※ Wearing bright-color clothes. Wear a safety helmet, meanwhile, also should choose suitable protective glasses.

※ Driving must be avoided under the condition of night lights dazzling, blind spots and without any alert.

2. Many traffic accidents occurred in road crossings, park lot entrance and carriageways. Therefore, when driving across those places, the drivers should be more cautious.

3. Speeding is a major factor in causing many traffic accidents. The drivers should observe speed regulations, absolutely must not drive with the excessive speeds.

4. Many accidents were closely related to the driving experience. The drivers who have just learned to drive should be safely familiar the every performance of the motorcycle, before driving on the highway. Never lend your motorcycle to others who do not have a driving license and are lack of driving experience.

5. The drivers should avoid driving through the rugged road, for which may lead to steering failure or body structures damage.

6. Before driving the motorcycle, the detailed checks must be conducted carefully.

7. While driving, both hands must hold the handlebar, and two feet should be put on the pedal.
8. While driving, calling or answering the phone, as the main cause of inattention, is likely to cause traffic accidents. Please stop your motorcycle first, then call or answer the phone.
9. Change lanes obtrusively is one of the important causes of traffic accidents. If the drivers need change lanes, please make a turning signal in advance, observe the rear vehicles, and then change lanes after confirming the safety.

Load

※Warning:

Glove compartment, shelves and other storage facilities, can only be placed with lighter objects. Weight of display objects should not exceed the stipulated value in table 1.

Table 1

Storage projects	Weight
Glove compartment	10kg

※When calculating the motorcycle's load-carrying capacity (maximum 150 kg) and estimating it is whether or not overloaded, the weight of goods and sundries contained in the motorcycle, the driver and crew should all add up to be counted.

※If the motorcycle is overloaded, it will affect its stability and operations.

※All objects mounted on the motorcycle should be fastened tightly.

II Position drawing of every machine part and operation manual

Diagrammatic sketch of components and parts

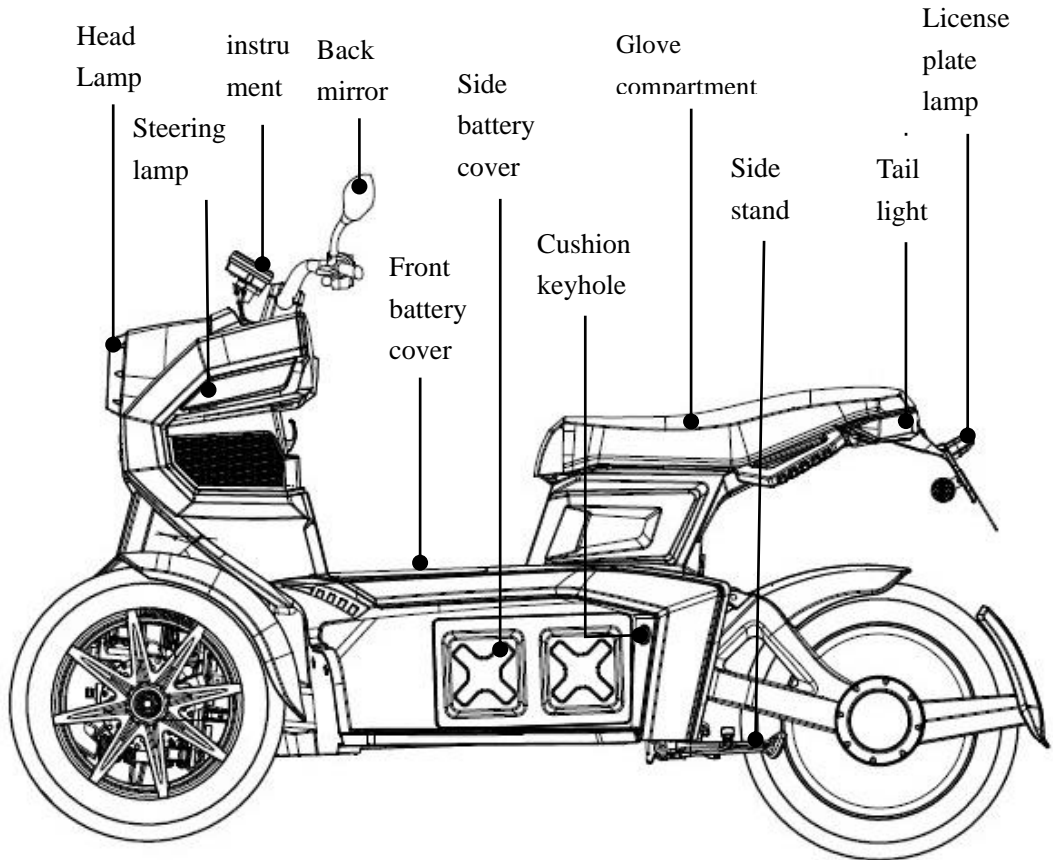

Diagrammatic sketch of components and parts

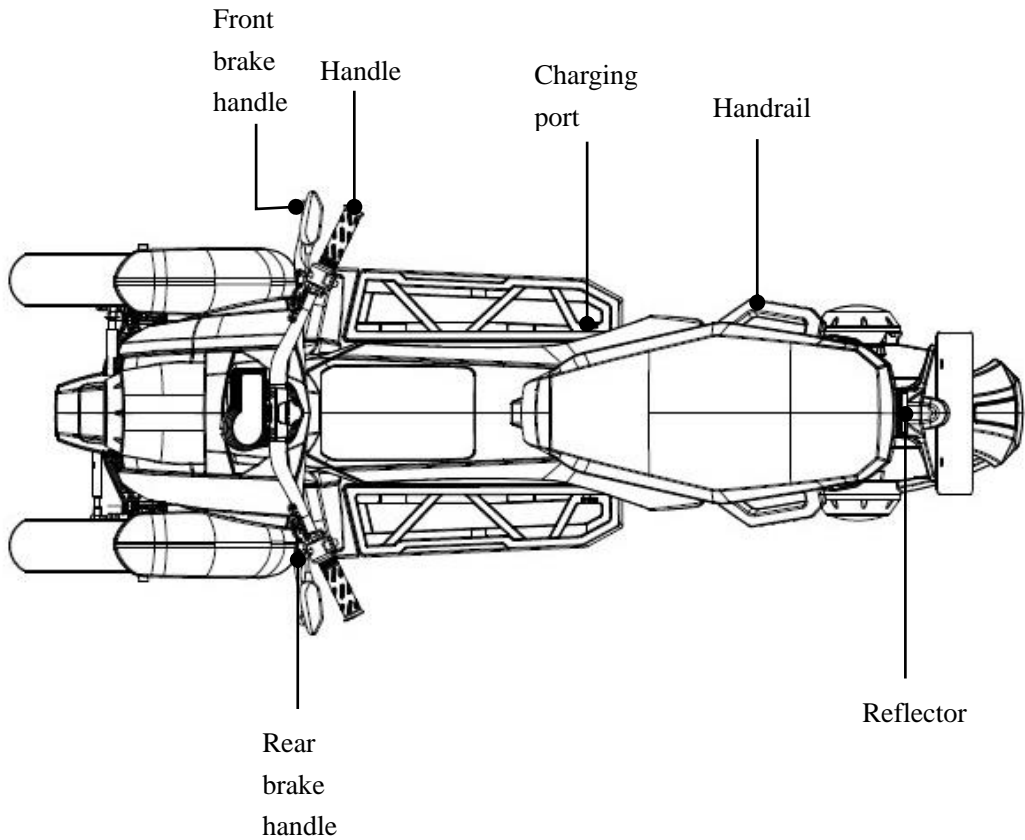

Instrument board illustration

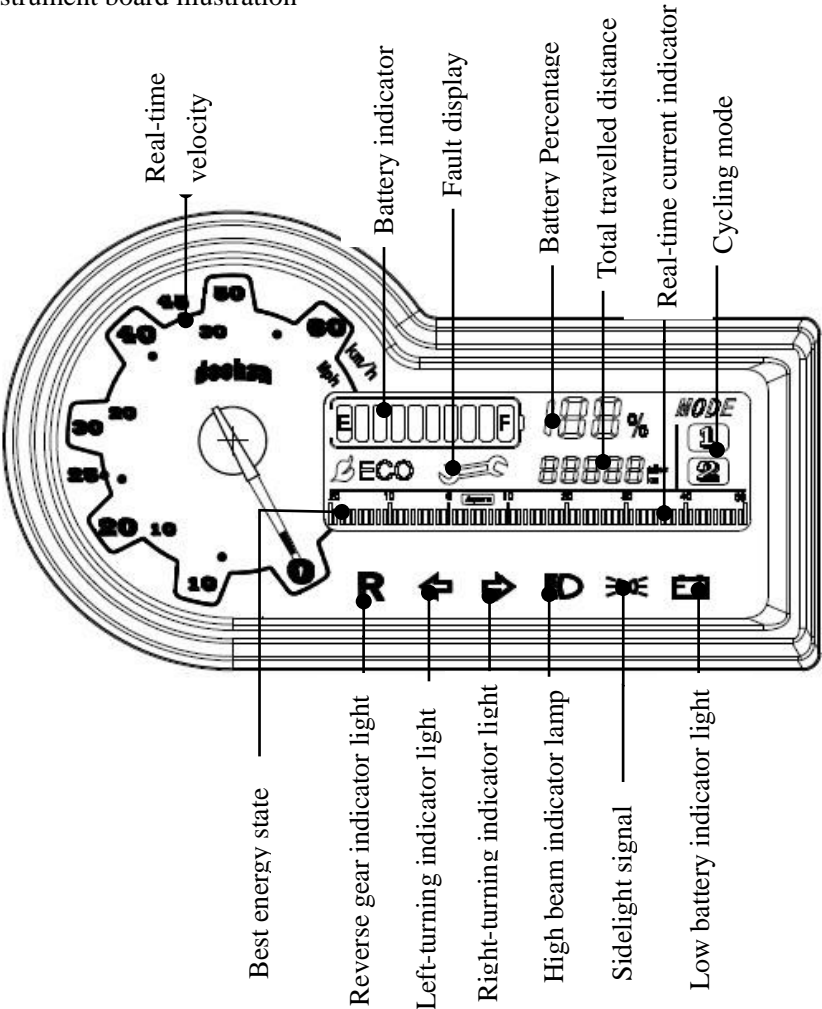

Icon illustration



Left-turning indicator light

Light up left-turning light



Right-turning indicator light

Light up right-turning light



High beam indicator lamp

Light up high beam indicator lamp



Sidelight signal

Light up sidelight of the front and back



Low battery indicator light

Electric quantity of battery is lower than 30%



Reverse gear indicator light

The motorcycle is in reverse gear state



Best energy state

The current percent conversion of energy reaches the ideal state.



Cycling mode

Now the motorcycle is in its cycling mode.



Real-time velocity

The total indicator reading means the current cycling speed.



Battery Percentage

It shows the current battery percentage.

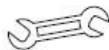

Fault display

It shows that some faults appear at present.

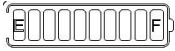

Battery indicator

It shows the current battery electricity, and per grid represents the 10% of full battery.

Low battery

Full battery



total travelled distance

It shows the total travelled distances of the motorcycle.



Real-time current indicator

According to the changes of real-time current value, it shows the condition of controller real-time power output.

Power switch:

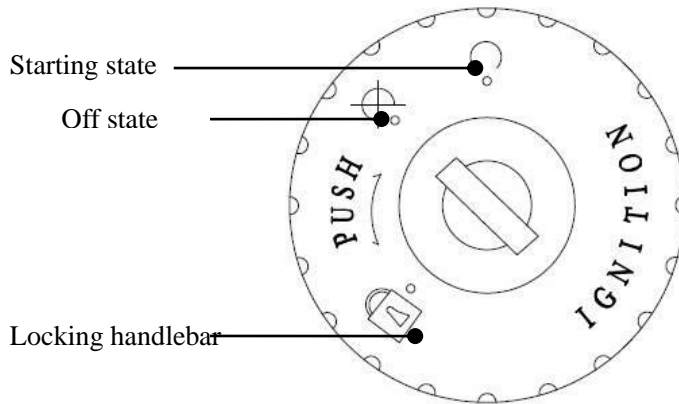

△ Starting up operation

- ① Hit the unlock key of remote control, and unlock successfully.
- ② After the confirmation of successful unlock, insert the key and turn to “” position. After that, the motorcycle can be started and keys cannot be pulled out.
- ③ When the self-test of system is complete, enter a waiting state.
- ④ Hold the brake handle, lift the kick stand, let go of the brakes when driving.

Right combination switches:

1. Back-up switch:

Dial up R for backing, dial down D for moving forward

2. Gear switch:

1 is the low gear 25km/h, and 2 is high gear 45km/h.

Gear switches can be used to interchange 25km/h and 45km/h.

3. Horn switch:

Press down this button, the horn will beep.

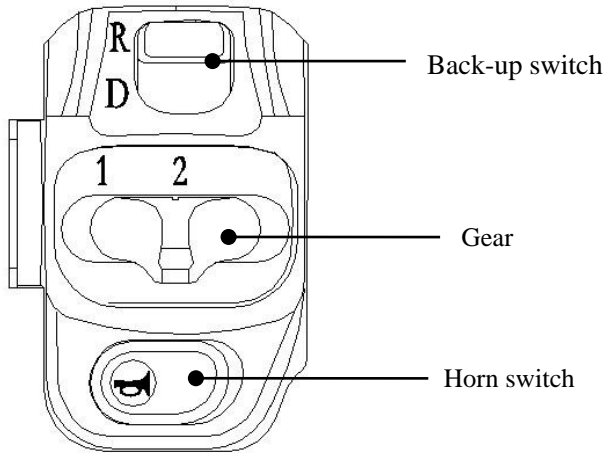

Left combination switches:

1. Headlight dimmer switch:



Press down “” to light up the distance indicator light;

Press down “” to light up the dipped headlight.

2. Overtake indicator light button

Press down this button, the overtake indicator light will be lit up.

3. Turning indicator lights button:

Turn left if the button is placed in “” position, and the left-turning light will be lit up at the same time. Turn right if the button is placed on the iron “”, and the right-turning light will be lit up at the same time. Press down the button again, turning indicator light will be turned off.

4. Horn switch:

Press down this button, the horn will beep immediately.

△ Functional area for placing objects

Remark: USB interface must not be used in any electrical appliances except phone chargers.

Otherwise, the factory shall not be responsible for any damage of machine parts.

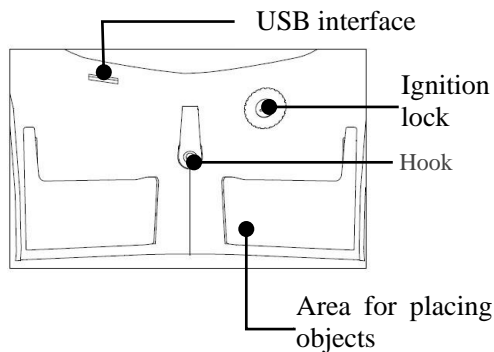
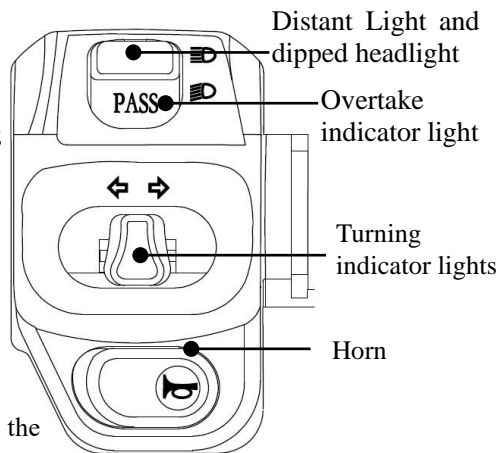

Battery Compartment Operation

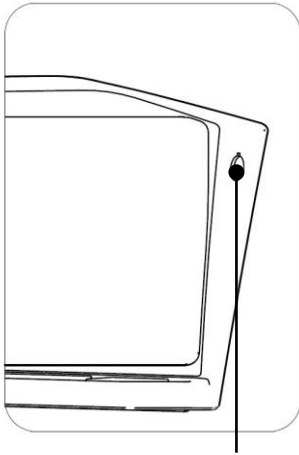

Keyhole of glove compartment

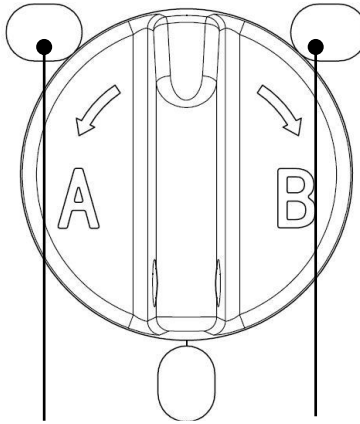

Open side battery compartment

Open front battery compartment

- ① Open glove compartment: insert the key into the keyhole of glove compartment, and reeling open the glove compartment cover.
- ② Open battery compartment: rotate the rotary knob to the corresponding position along the direction of B to open the lock of front battery compartment, and rotate along the corresponding direction of A to open the side battery compartment lock.

III、 Daily inspection and adjustment

Check before driving: :

Before driving the motorcycle, drivers should take a routine inspection to the intelligent electric motorcycles to ensure the good performance of the motorcycle and reach the effects of safe driving.

Brake handle free stroke

Appropriate clearance is necessary for the brake handles, And whose normal clearance should in the range of 10 to 20 millimeters. Fluid pressure type brake system

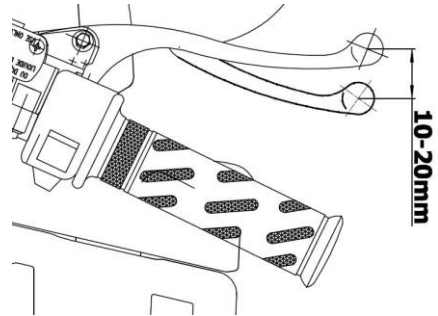

Brake fluid inspection:

- (1) Straighten the handle, and check brake fluid in the oil storage tank. The brake fluid must be maintained between the label marks of upper and lower limit.
- (2) Check the brake pads wear when brake fluid declines to the label mark of lower limit.
- (3) If the brake pads are abraded, and the brake fluid does not exceed the limitation, usually it indicates that oil leak exists. Please seek check and repair service from maintenance station.
- (4) Brake oil: DOT3 or DOT4

Notice: Once you need to maintain brakes, drivers should ask for the handy special maintenance department who is responsible for the maintenance and inspection of motorcycles. All special maintenance departments have trained technical personnel responsible for maintenance and repair. The motorcycle parts can only be changed with real original parts of the company.

Tires

The tire pressure should be inspected and adjusted routinely.

- Check the tire pressure only after cooling tires.
- Check often whether there are punctures in tires, especially tires need to be repaired immediately when tire air leakage occurs.
- Check whether there are shear marks, implant iron nails or other sharp objects in tire surfaces. Check whether or not the indentation, indenture or distortion of rims exists. If any damage has been caused, please contact the maintenance departments to check.
- If the tire tread patterns are worn to tread wear indicators, new tires should be required for changing.

Warning:

- Substandard tire pressure would make the tire treads suffer a serious abrasion and may cause accidents because of that. While much lower tire pressure would cause tire slip or pulling away from rims.
- It is extremely dangerous to use seriously worn tires, which would impact the adhesive forces between tires and the road surface, and make difficulties for driving and even cause accidents. Tires need to be changed to new tires when the central tread pattern depth of tires reaches the stipulation in table 1.

Table 1

Minimum tread pattern depth		Tire Pressure
front wheel	1.5 mm	250kpa
back wheel	2.0 mm	250kpa

Left-turning light, right-turning light, and the tail lamp

Left-turning light, right-turning light, and the tail lamp can normally work or not. If not, it should be replaced in time.

Horn

The horn can normally beep or not, if not, it should be timely adjusted or replaced.

Turning handle

Speed regulation of turning handle is effective and even or not and can automatically return or not.

IV、 Operation guidance

1. Starting, hold the handlebar with both hands, bestride the motorcycle from the left side and sit on the saddle with left leg support against ground, turn the power switch to ON and rotate the handlebar in the direction of the rider gradually instead rotate rapidly it to maximum.

Warning:

After the front and back wheels of the intelligent electric motorcycles is down to the ground, provided that the rider is not sitting on the saddle for riding, do not turn the power on and rotate the handlebar lest the motorcycle should rush out suddenly, even lead to accident.

2. Riding, obey the traffic rules, control the speed within 45km/h and operate the parts timely and accurately according to the riding environment.

Warning:

It is not advised to wear loose or unfit clothes when riding, otherwise the loose sleeves or trouser legs may hook the braking handles or jackstays parts.

Only when all kinds of equipments installed on the right three-wheel electric motorcycle are in line with the requirements of traffic laws and regulations issued by local government and carry the entire necessary certificates according to the requirements and stipulations, then you can ride out.

4. Parking

① Rotate anticlockwise the key to state after reach the destination and the entire motorcycle will power off, then remove the key.

② Make the side shoring be parking state and the motorcycle inclines to left with side shoring supported. Turn the handle to the end of left, rotate the key anticlockwise to state and remove the key. By then, It cannot be conducted steering operation and the motor as well as various lights is unable to light up.

5. Locking

Locking operation is allowed only when the key is in and state. Press the “lock” key in the effective distance after the motorcycle parked and after the turn lights light for several seconds the motorcycle locked successfully.

6. Looking for motorcycle

Press the “motorcycle locating” key and the turn lights can twinkle for ten seconds, in case of no-operation, the acoustic-optical function notes for ten seconds which can be relieved by lock key or unlock key. Return the handlebar and cease the motorcycle with brake handles clenched, support the ground with right leg first, turn the power lock to OFF then support the motorcycle with the kickstand.

Prevention of burglary key points

- Lock well the handlebar timely and never leave the key in the power keyhole.
- Park the motorcycle into the garage with lock if possible.
- Adopt additional anti-theft device of high quality.

5 Braking operation

(1) Control speed

This is very significant that in case of speed reduction of the intelligent electric motorcycles, control the rotation, coordinate the operation of the front and back brakes.

Warning: when riding on humid or loose road or in rainy day, pay more attention whether braking, speeding up or steering.

(2) Concurrent operation of the front and back brakes

Attention: when riding on a steep slope, return the handlebar completely, use the front and back brakes to reduce the speed. Avoid successively operate the brakes, otherwise the brakes will heat too much result in reducing the braking effect.

Warning: do not solely use the front brake or back brake when riding on wet road or curve road at medium and high speed, use the both brakes at the same time lest should lead to sideslip accidents.

6. Charging

Motorcycle charging

① Open the motorcycle charging port by turning the cover, insert the charging plug into recharge socket until you hear “click” which means that the charging plug has connected with the socket, then connect the charger’s input with electric supply. The indicator light turns green to red means it starts charging and on the contrary, it is fully charged.

② The instrument can display the current electric quantity when turn power on while charging.

Extra position charging

① Open the batteries compartments (see specific methods in graphic illustration set forth above)

③ Take the batteries out from the motorcycle.

③ Insert the charging plug into recharge socket until you hear “click” which means that the charging plug has connected with the socket, then connect the charger input with electric supply. The indicator light turns green to red means it starts charging and on the contrary, it is fully charged.

Attention:

If the batteries cannot be fully charged after more than 10 hours charging, please stop charge and contact the aftersales department for maintenance.

In order to expand the batteries' maximum service life, circularly use it with the scope of batteries quantity between 20%-80% if possible.

Please do not store the batteries to the place with temperature of 40°C above which may lead irreversible capacity fading.

The lithium battery capacity may cause fading inordinately at low temperatures. Specific reference degrees: available capacity is 70% at -10°C, 80% at -0°C and 100% at 25°C.

The most suitable electric quantity for battery storage is 50%. Long-term storage with electric quantity of less than 10% or more than 90% may lead irreversible capacity fading. In case of long-term battery storage, please maintain the batteries are in -10°C~30°C and conduct a complete charge-discharge cycling every two months which could reduce the storage attenuation at the most extent.

Avoid store the batteries to the places where are in risk of falling, provided that battery falling could lead uncontrolled damage inside batteries and result in batteries leaking, heating, and smoking, even fire disaster or explosion.

V、 Maintenance and repair

In order to expend the motorcycle's service life and have a safety and comfortable ride, please check and maintain the right three-wheel electric motorcycle regularly even if it has been placed for a long term.

1. Scheduled maintenance and repair

It is required to have first maintenance after one month or 500km since purchase and go to aftersales department for complete maintenance and inspection every six months or 3000km after that, which can maintain your motorcycle in best safety state and ensure the safety of the rider as well as the motorcycle.

Attention:

In case of full load, over load, high speed driving or ride on bumpy road, uphill or downhill usage states, please cut down the maintenance period.

Please use original parts in case of maintenance, which are produced with good materials and have passed the strict examination with guarantee of quality and service life, can ensure the motorcycle in best state and your traffic safety, as well as normal after service.

Routine maintenance

In case of abnormalities, which need clean, maintain or replace timely, can refer to simple maintenance methods or send back to dealer for checking.

Warning: for your own safety, in the event that you cannot repair or adjust the motorcycle, please send back to dealer for maintenance.

Please repair and adjust the motorcycle on flat road with kickstand set up, if it is necessary to check while riding, pay attention to traffic safety.

2. Motorcycle cleaning

Please clean the motorcycle with water joined neutral detergent and scrub it with soft cloth avoid dry rub, which could cause scratch.

Warning:

When cleaning, please ensure turn power off and remove the key prior to pull the plug; Please do not flush the both sides and inner of the battery holder directly with water torch and avoid flushing the charger and controller parts, which are in the side cover above the back wheel lest they are broken down with water flowed in.

There is AC high voltage in the charger, if the motorcycle dumps when cleaning, the water may flow into the charger, to avoid electric shock, and please do not charge directly until it is dry. It is advised to go to the maintenance points for checking and drive after the confirmation.

Periodic Maintenance and Inspection Items			
Regular safety and performance inspection	Brake	Construction check	Wheel bearing
	lamplight		Shock absorber
	Horn		Main jiffy stand
	Electronic parts		Steering bearing
	Fuse wire	Major parts	Battery
	Tire		Main harness
Construction check	Lubrication		Control system

3. Using tips for the usage of the whole motorcycle

1. Please twirl the handle evenly when start, avoiding speed up rapidly, to ensure driving safety and can protect the motor and batteries at the same time.
2. Please ride in low-speed or walk the motorcycle when running on the uphill, upwind, muddy road or with load, which can avoid batteries high current discharge, promote the distance per charge and extend the battery service life.
3. Please switch the power to OFF-range and remove the key before leaving.
4. Please develop the habit that loosen the handle to original position when braking; if the handle is still at the working position, once release the brake, the motor will receive electric current to revolve immediately which is not conducive to safety.

5. Although the intelligent electric motorcycles has a good rainproof capability, please avoid direct sun and rain, lest the corrosion of motorcycle body or rotating parts; using in rainy day, the wheel hub should not be covered above axle centerline, lest motor is broken down with water flowed in.

6. Please scrub the motorcycle, clear the surface of motor and other parts and keep clean; do not scour the electric parts and drive parts with water directly.

7. Try to avoid parking the motorcycle in the place with direct sunshine, high temperature and moist or parking outside in rainy day; moreover, protect the govern handle, battery holder and control box. Provided any of above situations occurred, please try turning to ensure its normal prior to ride.

8. The front fork, epipodium and backshaft components should be lubricated (grease) regularly at least once a year and brake cables of front and back should be lubricated frequently to insure its dexterity.

9. Check before driving.

It is required to check the following items, which are very important, before driving the motorcycle.

Content inspection	extensive search
handlebar	1) Stationary 2) Flexible rotation 3) No axial float and loose
Braking	1) The brake handle has a idle running of 10-20mm. 2) The tire pressures of wheels are 250 kPa
Tire	1) The tire pressures are normal 2) Proper tire stripe 3) Without cracks or wounds
Battery	Enough electric quantity for planned distance
Lamps	Operate all the lamps: distant Light、dipped headlight、brake lamp、turn light etc.
Horn	Check the trumpet for abnormalities

10. The following items are advised for best driving range:

- a. Try to reduce the times of braking and start under the condition of safety.
- b. Speed up evenly at startup time, keep at low-speed of 20km/h when driving and release the handle to self-return when brake.
- c. Please walk the motorcycle when meet with uphill, muddy or upwind road.
- d. Do not overload.

11. The motorcycle has been checked out when delivery and unauthorized modification is not allowed, the factory is not responsible for the significant problems caused by above reason.

4. Using tips for motor and controller

1. Please do not speed up rapidly when start at zero speed or on the uphill, muddy or upwind road, lest cause incremental losses of motor and accumulator.
2. Intelligent electric motorcycle is not suitable for running on the road of irregularity or craggedness, which could cause bad contact among electric parts, please ride in low-speed or walk it if meet with such roads.
3. Please maintain the surface of motor and controller clear for long-term, avoiding washing by water directly.
4. Do not disassemble the motor and controller without approval; in case of maintenance or replacement, please go to the local dealer or the assign maintenance points.

5. Instruction for usage and maintenance of batteries

Battery using environment

Please use the battery under the environment temperature of $-10^{\circ}\text{C}\sim 45^{\circ}\text{C}$.

Please prevent the batteries from water, drinks or corrosive liquid, which may cause batteries leaking, heating, and smoking, even fire disaster or explosion.

Please prevent the batteries from heat source, naked fire, combustible and explosive gas, which may cause batteries leaking, heating, and smoking, even fire disaster or explosion.

If some metal enter the battery holder, it may cause batteries leaking, heating, and smoking, even fire

disaster or explosion.

In case of the batteries have peculiar smell, emit heat or are out of shape, please cease using immediately, keep away from the batteries and contact after sales department.

Warning: Batteries are not belongs to the assembly units which users can repair by their selves, in case of fault, please contact the after sales department for maintenance, disassemble batteries without approval may cause batteries leaking, heating, and smoking, even fire disaster or explosion.

6. Using tips for charger

1. Please charge the batteries under the environment temperature of $0^{\circ}\text{C}\sim 35^{\circ}\text{C}$
2. Please do not charge the batteries for more than 10 hours; otherwise, it will reduce the batteries' service life.
3. The batteries should be charged with matched special charger installed on vehicle. When charging, insert the output plug of the charger into the motorcycle's outlet until hear a sound of "click", which means the charging plug has connected with the outlet, then insert the input plug of the charger into alternating current power supply. Moreover, when the batteries is fully charged, pull out the input plug prior to output plug, order of which is required.
4. In order to ventilate and dissipate the heat, it is prohibited to cover any other things on the charger and battery holder when charging.

5. The charger should be stored in dry and ventilated place and do not jolt or collide in case of carrying; otherwise, it will lead to breakdown.
6. Miniwatt AC voltage stabilizer is advised to use in areas of voltage instability; otherwise, it may cause that the batteries are undercharge or the charger breaks down.
7. Do not disassemble the charger without approval; in case of replacement, please go to the local dealer or the assign maintenance points for replacement.

Attention:

1. When using the motorcycle, please ensure that the battery plug has connected with the battery properly and hear a sound of “click” while insert the plug; otherwise, it may occur bad contact and affect riding.
2. The function of charging below 0°C has turned off, please charge the batteries under the environment temperature of 0°C above.

Warning: using non-original charger may cause batteries leaking, heating, and smoking, even fire disaster or explosion.

VI、 Common Fault and elimination methods

Reference Disposal Method for Common Fault		
Fault phenomenon	Fault cause	Elimination methods
<p>Turn power on, but the entire motorcycle has no power output</p>	<ol style="list-style-type: none"> 1. Battery plug isn't inserted properly; 2. Key switch is breakdown; 3. Batteries run out. 4. Battery is breakdown 5. Blown fuse 	<ol style="list-style-type: none"> 1. Remove the key and reinsert the plug. 2. Replace electric door lock 3. Charge the batteries 4. Replace battery 5. Replace fuse
<p>Turn power on and twirl the governor handle, but the motor cannot start</p>	<ol style="list-style-type: none"> 1. Low battery voltage 2. Half-hold the bike crank lead to activation of outage switch. 3. The motorcycle is not started. 4. The kickstand is not pulled. 5. The governor handle is not reset. 6. The fault-indicating lamp is flickering. 	<ol style="list-style-type: none"> 1. Charge the batteries 2. Do not hold the bike crank when start. 3. Refer to the "starting operation" section in manual. 4. Pull up the kickstand. 5. Reset the governor handle. 6. Dispose according to the APP fault code.

Running speed is low or distance per charge is short	<ol style="list-style-type: none"> 1. Low battery power 2. Low tire pressure 3. Too often braking and start or overload 4. Aged or normally damped batteries. 5. Under low-temperature environment, the charge-discharge capability weakens. 	<ol style="list-style-type: none"> 1. The charger is breakdown. 2. Check the tire pressure before using. 3. Develop good driving habits. 4. Replace the batteries 5. Normal phenomenon
The batteries cannot be charged	Bad contact between charger plug and outlet or the charger is breakdown.	Check the plug for looseness or replace the charger.
Ceases when riding	Batteries run out.	Charge the batteries

Inquire APP fault of mobile phone and find out the reason through instrument fault indication	
Instrument display spanner	Conduct examination through mobile phone APP to know the fault reason or go to the maintenance point.

VII. Motorcycle Storage

Storage

Short-term Storage:

- 1) Please store the motorcycle on flat place with good ventilation and desiccation;
- 2) In order to insure the batteries' service life, please charge them to at least 50% prior to store it;
- 3) Try to prevent the motorcycle from sun and rain, which can help reduce damages or aging of the parts;
- 4) Please charge fully when using after long-term storage;
- 5) When intensively store the motorcycles with batteries installed in indoor, exhibition hall, storehouse and other safety places or transport them in short-distance by goods stocks, please turn the power off and remove the key, then pull out the plug of the batteries so as to avoid electrical fault.

Long-term Storage:

- 1) When long term stored, please turn the power off and remove the key, then pull out the plug of the batteries to disconnect the batteries' power supply circuit in order to prevent the batteries from over discharge;
- 2) When long term stored, please conduct a complete charge-discharge cycles to the batteries every two months and charge them to at least 50% prior to store it for their service life;
- 3) Please charge fully when using after long-term storage;
- 4) Please check the various parts of the motorcycle for abnormalities prior to ride, if there are some abnormalities, send it back to the dealers for maintenance or inspection.

VIII、 Vehicle Identification

Vehicle model, number and label position of the products

The intelligent electric motorcycles VIN and Motor number are required to present when registration, receiving driving license and annual verification, as well as reparation or replacement of parts in the “three guarantee” period which the above numbers should be available to refer.

The rivet for nameplate of the product is on the right of the mounting plate.

1 VIN print position

2 Motor Number position

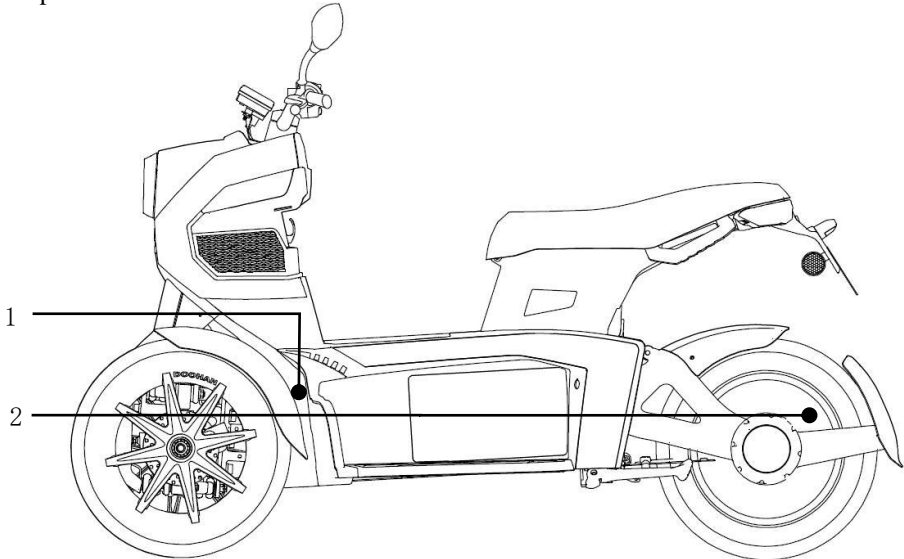

IX、 Main technical data

Main dimension			
vehicle length	1780mm	vehicle width	730mm
vehicle height	1030mm	Wheelbase	1250mm
Track front	460mm		
Main performance			
Curb weight	99kg	Designed maximum speed	First gear 25km/h
Rated voltage	60V		Second gear 45km/h
Maximum Payload	160kg	Braking distance (dry land)	≤2m(20km/h) ≤3.5m(30km/h)
Personnel quota	1 person		
Climbing ability	≥25% (Load 80KG)	Braking distance (wet land)	≤3m(20km/h) ≤4m(30km/h)
The standard power consumption	1.7KW/h		
Economical distance per charge	100KM(20km/h)		
Frame			
front shock absorber		Sleeve、 Oil Damping Type	
rear shock absorber		Sleeve、 Oil Damping Type	
Front tire Type		80/100-12×2	
Rear tire Type		120/70-12	
Front Brake Mode		160mm Rotor Double-piston Hydraulic Disk	
Rear Brake Mode		190mm Rotor Double-piston Hydraulic Disk	

Minimum Ground Clearance	130mm
saddle height	750mm
Max angle of leaning	$\leq 30^\circ$
Max angle of steering	$\leq 34^\circ$
Maximum Range of the Head in the Front Wheels	183mm
Battery system	
Battery type	18650 Ternary Lithium Battery
Voltage	60V
Capacity	26AH
Standard charge current	4A
Maximum discharge current	75A
Standard charge time	6H~7H
Biggest continue voyage course	100KM (20km/h)
Power Capacity of Single Battery	2600mAh
Battery Weight	9KG
Charge and discharge of battery	600 times
Ambient temperature range of battery use	-20℃ to 60℃
Ambient temperature range of battery storage	-20℃ to 60℃
Ambient temperature range of battery charging	0℃ to 45℃
Battery protection system	Over discharge protection、 short-circuit protection、 temperature protection、 overcharge protection、 overcurrent protection、 balance

	protection of battery
Cover plate material of the Battery Compartment	Aluminum plate
Power system	
Motor type	BOSCH custom motor
Motor controller	Sine wave controller
Maximum rotation rate/idling power/efficiency	522rpm/10W/6.7%
Rated power/rotation rate/efficiency	1541W/509rpm/88.1%
Maximum power/rotation rate/efficiency	1852W/466rpm/88%
Maximum torque/rotation rate/efficiency	128N·m/19rpm13.7%
Maximum energy recovery	10%~15%
Maximum current of controller	35A
Motor energy utilization rate	88.7%
Others	
Headlamp	LED、5W
USB charging port	5V、1A

X、Electrical schematic diagram

